

Intelligent Photoelectric Smoke Detector

Model SIGA-PS

Note: Some features described here may not be supported by all control systems. Check your control panel's Installation and Operation Guide for details.

Features

- Integral microprocessor
- Non-volatile memory
- Automatic mapping device
- Electronic addressing
- Environmental compensation
- Intelligent detector
- Wide 0.67% to 3.77%/ft. sensitivity range
- Twenty pre-alarm sensitivity values, set in 5% increments¹
- Identification of dirty or defective detectors
- Automatic day/night sensitivity adjustment
- Twin RED/GREEN status LEDs
- Standard, relay, fault isolator, and audible mounting bases
- Designed and manufactured to ISO 9001 standards

Description

EST's Signature Series Model SIGA-PS Intelligent Photoelectric Smoke Detector gathers analog information from its smoke sensing element and converts it into digital signals. The detector's on-board microprocessor measures and analyzes these signals. It compares the information to historical readings and time patterns to make an alarm decision. Digital filters remove signal patterns that are not typical of fires. Unwanted alarms are virtually eliminated.

The microprocessor in each detector provides four additional benefits - **Self-diagnostics and History Log, Automatic Device Mapping, Stand-alone Operation and Fast, Stable Communication.**

Self-diagnostics and History Log - Each Signature Series detector constantly runs self-checks to provide important maintenance information. The results of the self-check are automatically updated and permanently stored in the detector's non-volatile memory. This information is accessible for review any time at the control panel, PC, or by using the SIGA-PRO Signature Program/Service Tool.

¹ EST3 V.2 only.

² Retrievable with SIGA-PRO programming tool.



The information stored in the detector's memory includes:

- detector type, serial number, and address
- date of manufacture, hours of operation, and last maintenance date²
- current detector sensitivity and environmental compensation values
- original detector sensitivity values upon manufacturing²
- number of recorded alarms and troubles²
- time and date of last alarm¹
- analog signal patterns just before the last alarm¹
- most recent trouble code logged by the detector — 32 possible trouble codes may be used to diagnose faults.

In the unlikely event that an unwanted alarm does take place, the control panel's history file can be called up to help isolate the problem and prevent it from happening again.

Automatic Device Mapping - The loop controller learns where each device's serial number address is installed relative to other devices on the circuit. The mapping feature provides supervision of each device's installed location to prevent a detector from being reinstalled (after cleaning etc.) in a different location from where it was originally. The history log for the detector remains relevant and intact regardless of its new location.

The Signature Series Data Entry Program also uses the mapping feature. With interactive menus and graphic support, the wired circuits between each device can be examined. Layout or "as-built" drawing information showing wire branches (T-taps), device types and their address are stored on disk for printing hard copy. This takes the mystery out of the installation. The preparation of "as-built" drawings is fast and efficient.

Device mapping allows the Signature loop controller to discover:

- unexpected additional device addresses
- missing device addresses
- changes to the wiring in the circuit.

Stand-alone Operation: A decentralized alarm decision by the detector is guaranteed. On-board intelligence permits the detector to operate in stand-alone mode. If loop controller CPU communications fail for more than four seconds, all devices on that circuit go into stand-alone mode. The circuit acts like a conventional alarm receiving circuit. Each detector on the circuit continues to collect and analyze information from its surroundings. The detector alarms if the preset smoke obscuration level is reached. If the detector is mounted to a relay base, the relay operates. Similarly, if it is mounted to an audible base, the on-board horn sounds.

Fast Stable Communication: On-board intelligence means less information needs to be sent between the detector and the loop controller. Other than regular supervisory polling response, the detector only needs to communicate with the loop controller when it has something new to report. This provides very fast response time and allows a lower baud rate (speed) to be used for communication on the loop. The lower baud rate offers several advantages including:

- less sensitivity to circuit wire characteristics
- less sensitivity to noise glitches on the cable
- less emitted noise from the data wiring
- twisted or shielded wiring is not required.

Electronic Addressing: The loop controller electronically addresses each detector, saving valuable time during system commissioning. Setting complicated switches or dials is not required. Each detector has its own unique serial number stored in its "on-board memory". The loop controller identifies each device on the circuit and assigns a "soft" address to that device's serial number. If desired, detectors can be addressed using the SIGA-PRO Signature Program/Service Tool.

Environmental Compensation: Detection sensitivity is virtually independent of its installed environment and its physical condition. Environmental compensation means the sensing element adapts to long-term changes caused by dirt, humidity, aging etc. It even com-pensates for small amounts of normal ambient smoke. Approximately six times every hour the detector adjusts and updates the sensitivity (% obscuration) baseline for its sensing element. Approximately once every hour this information is written to its permanent memory. The detector's "learned" baseline is not lost, even when the detector is removed for cleaning. *Signature Series environmental compenstion is so reliable that it meets NFPA72 field sensitivity testing requirements — without the need for external meters.*

The detector's sensitivity setting selected by the installer floats up or down to remain constant relative to the changing baseline. This is called differential sensing.

Sensitivity Range: The SIGA-PS Photoelectric Detector has a sensitivity range or window of 0.67% to 3.77%. The installer selects the detector's ALARM sensitivity level from five available settings within the range.

Pre-Alarm: The detector stores one of 20 pre-alarm sensitivity values to alert local personnel prior to the sensor reaching a full evacuation sensitivity. Sensitivity values can be set in 5% increments.¹

Automatic Day/Night Sensitivity Selection: Signature Series detectors may be programmed for different sensitivities during day and night periods. This allows the detector to be more sensitive during unoccupied periods when lower ambient background conditions are expected.

Stability: The SIGA-PS detector's sensitivity remains stable in wind velocities up to 5,000 ft/min (25.3 m/sec). Ambient temperature has very little affect on the detector. The detector may be installed in rooms with ambient temperatures up to 120°F (49°C).

Status LEDs: Twin LEDs are visible from any direction. A flashing GREEN LED shows normal system polling from the loop controller. A flashing RED LED means the detector is in alarm state. Both LEDs on steady shows alarm state - stand-alone mode. Normal GREEN LED activity is not distracting to building occupants, but can be quickly spotted by a maintenance technician.

Quality and Reliability: GE Security detectors are manufactured in North America to strict international ISO 9001 standards. All electronics utilize surface mount technology (SMT) for smaller size and greater immunity to RF noise. A conformal coating is used for humidity and corrosion resistance. All critical contacts are gold plated.

Installation

Signature Series detectors mount to North American 1-gang boxes, 3-1/2 inch or 4 inch octagon boxes, and to 4 inch square electrical boxes 1-1/2 inches (38 mm) deep. They mount to European BESA and 1-gang boxes with 60.3 mm fixing centers.

Testing & Maintenance

Each detector automatically identifies when it is dirty or defective and causes a "dirty detector" message. The detector's sensitivity measurement can also be transmitted to the loop controller. A sensitivity report

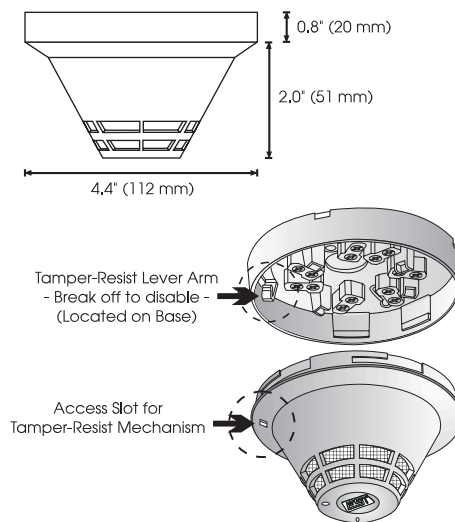

can be printed to satisfy NFPA sensitivity measurements which must be conducted at the end of the first year and every two years thereafter.

The user-friendly maintenance program shows the current state of each detector and other pertinent messages. Single detectors may be turned off temporarily from the control panel. Availability of maintenance features is dependent on the fire alarm system used. Scheduled maintenance (Regular or Selected) for proper detector operation should be planned to meet the requirements of the Authority Having Jurisdiction (AHJ). Refer to current NFPA 72 and UL CAN/ULC 536 standards.

Compatibility

The SIGA-PS detectors are compatible only with EST's Signature Loop Controller.

¹ EST3 V.2 only.

Application

Although photoelectric detectors have a wide range of fire sensing capabilities they are best suited for detecting slow, smoldering fires. The table below shows six standard test fires used to rate the sensitivity of smoke and heat detectors. The table indicates that no single sensing element is suited for all test fires.

GE Security recommends that this detector be installed according to latest recognized edition of national and local fire alarm codes.

Test Fire	Type of Detector				
	SIGA-IS Ion	SIGA-PS Photo	SIGA-HRS and SIGA-HFS Rate-of-Rise/Fixed Temp.	SIGA-PHS Photo/Heat 3D	SIGA-IPHS Ion/Photo/Heat 4D
Open Wood	optimum	unsuitable	optimum	very suitable	optimum
Wood Pyrolysis	suitable	optimum	unsuitable	optimum	optimum
Smouldering Cotton	very suitable	optimum	unsuitable	optimum	optimum
Poly Urethane Foam	very suitable	very suitable	suitable	very suitable	optimum
n-Heptane	optimum	very suitable	very suitable	optimum	optimum
Liquid Fire without Smoke	unsuitable	unsuitable	optimum	very suitable	very suitable

Typical Wiring

The detector mounting bases accept #18 AWG (0.75mm²), #16 (1.0mm²), #14 AWG (1.5mm²), and #12 AWG (2.5mm²) wire sizes.

Note: Sizes #16 AWG (1.0mm²) and #18 AWG (0.75mm²) are preferred for ease of installation. See Signature Loop Controller catalog sheet for detailed wiring requirement specifications.

Standard Detector Base, SIGA-SB, SIGA-SB4

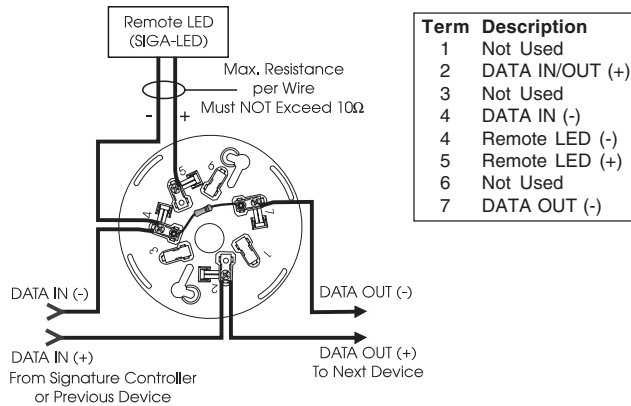

Relay Detector Base, SIGA-RB, SIGA-RB4

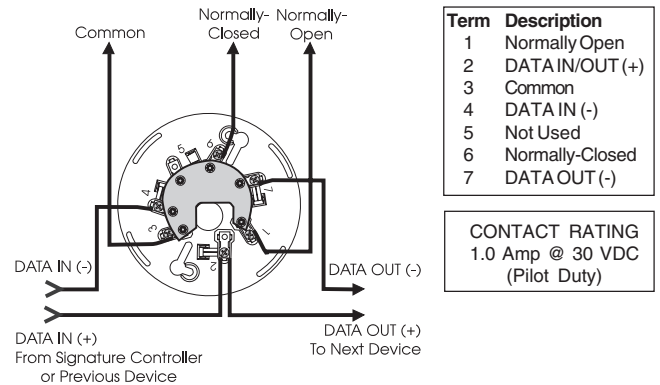

Isolator Detector Base, SIGA-IB, SIGA-IB4

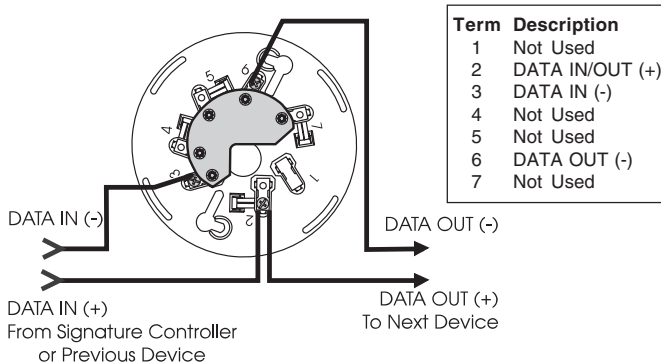

Audible Detector Base, SIGA-AB4G

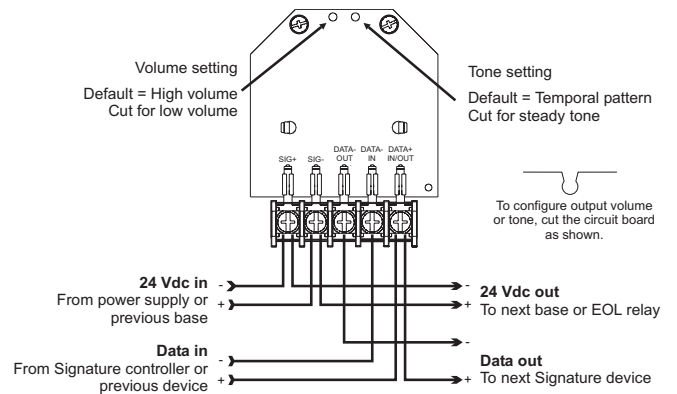

Accessories

All detector mounting bases have wiring terminals that are accessible from the "room-side" after mounting the base to the electrical box. The bases mount to North American 1-gang boxes and to 3½ inch or 4 inch octagon boxes, 1½ inches (38 mm) deep. They also mount to European BESA and 1-gang boxes with 60.3 mm fixing centers. The SIGA-SB4, SIGA-RB4, and SIGA-IB4 mount to North American 4 inch sq. electrical boxes in addition to the above boxes. They include the SIGA-TS4 Trim Skirt which is used to cover the "mounting ears" on the base. The SIGA-AB4G mounts to a 4" square box only.



Standard Base SIGA-SB, SIGA-SB4 - This is the basic mounting base for GE Security Signature Series detectors. The SIGA-LED Remote LED is supported by the Standard Base.

Relay Base SIGA-RB, SIGA-RB4 - This base includes a relay. Normally open or closed operation is selected during installation. The dry contact is rated for 1 amp (pilot duty) @ 30 Vdc. The relay's position is supervised to avoid accidentally jarring it out of position. The SIGA-RB can be operated as a control relay if programmed to do so at the control panel (EST3 V.2 only). The relay base does not support the SIGA-LED Remote LED.

Audible Base SIGA-AB4G - This base is designed for use where localized or group alarm signaling is required. When the detector senses an alarm condition, the audible base emits a local alarm signal. The optional SIGA-CRR Polarity Reversal Relay can be used for sounding to other audible bases on the same 24 Vdc circuit.

Relay and Audible Bases operate as follows:

- at system power-up or reset, the relay is de-energized
- when a detector is installed in the base with the power on, the relay energizes for four seconds, then de-energizes
- when a detector is removed from a base with the power on, the relay is de-energized
- when the detector enters the alarm state, the relay is energized.

Isolator Base SIGA-IB, SIGA-IB4 - This base includes a built-in line fault isolator for use on Class A circuits. A detector must be installed for it to operate. The isolator base does not support the SIGA-LED Remote LED.

The isolator operates as follows:

- a short on the line causes all isolators to open within 23 msec
- at 10 msec intervals, beginning on one side of the Class A circuit nearest the loop controller, the isolators close to provide the next isolator down the line with power
- when the isolator next to the short closes, reopens within 10 msec.

The process repeats beginning on the other side of the loop controller.

Remote LED SIGA-LED - The remote LED connects to the SIGA-SB or SIGA-SB4 Standard Base only. It features a North American size 1-gang plastic faceplate with a white finish and red alarm LED.

SIGA-TS4 Trim Skirt - Supplied with 4 inch bases, it can also be ordered separately to use with the other bases to help hide surface imperfections not covered by the smaller bases.

Warnings & Cautions

This detector will not operate without electrical power. As fires frequently cause power interruption, we suggest you discuss further safeguards with your fire protection specialist.

This detector will NOT sense fires that start in areas where smoke cannot reach the detector. Smoke from fires in walls, roofs, or on the opposite side of closed doors may not reach the detector to alarm it.

Specifications

Catalog Number	SIGA-PS
Sensing Element	Photoelectric - Light Scattering Principle
Storage & Operating Environment	Air Velocity Range: 0 to 5,000 ft/min (0 to 25.39 m/s); Humidity: 0 to 93% RH, Non-Condensing Operating Temp: 32°F to 120°F (0°C to 49°C); Storage Temp: -4°F to 140°F (-20°C to 60°C)
Sensitivity Range	ULI/ULC - 0.67% to 3.77% obscuration/foot
User Selected Alarm Sensitivity Settings	Most Sensitive: 1.0%/ft.; More Sensitive: 2.0%/ft.; Normal: 2.5%/ft.; Less Sensitive: 3.0%/ft.; Least Sensitive: 3.5%/ft.
Pre-alarm Sensitivity	5% increments, allowing up to 20 pre-alarm settings
Operating Voltage	15.2 to 19.95 Vdc (19 Vdc nominal)
Operating Current	Quiescent: 45µA @ 19 V; Alarm: 45µA @ 19 V Emergency Stand-alone Alarm Mode: 18mA Pulse Current: 100 µA (100 msec); During Communication: 9 mA max.
Construction & Finish	High Impact Engineering Polymer - White
Compatible Mounting Bases	SIGA-SB Standard Base, SIGA-RB Relay Base, SIGA-IB Isolator Base, SIGA-AB4, SIGA-AB4G Audible Bases
LED Operation	On-board Green LED - Flashes when polled; On-board Red LED - Flashes when in alarm Both LEDs - Glow steady when in alarm (stand-alone) Compatible Remote Red LED (model SIGA-LED) Flashes when in alarm
Compatibility	Use With: SIGNATURE Loop Controller
Address Requirements	Uses one Device Address
Agency Listings	UL, ULC, MEA, CSFM
UL Listed Spacing	30 ft

Ordering Information

Catalog Number	Description	Ship Wt. lbs (kg)
SIGA-PS	Intelligent Photoelectric Detector - UL/ULC Listed	.5 (.23)
Accessories		
SIGA-SB	Detector Mounting Base - Standard	.2 (.09)
SIGA-SB4	4-inch Detector Mounting Base c/w SIGA-TS4 Trim Skirt	
SIGA-RB	Detector Mounting Base w/Relay	
SIGA-RB4	4-inch Detector Mounting Base w/Relay, c/w SIGA-TS4 Trim Skirt	
SIGA-IB	Detector Mounting Base w/Fault Isolator	
SIGA-IB4	4-inch Detector Mounting Base w/ Fault Isolator, c/w SIGA-TS4 Trim Skirt	.3 (0.15)
SIGA-LED	Remote Alarm LED	
SIGA-AB4G	Audible (Sunder) Base	
SIGA-TS4	Trim Skirt (supplied with 4-inch bases)	.1 (.04)

www.gesecurity.com

It is our intention to keep the product information current and accurate. We can not cover specific applications or anticipate all requirements. All specifications are subject to change without notice. For more information or questions relative to this Specification Sheet, contact GE Security.